

Initial Specification for MicroMouse Motor Control Unit (MMCU)

A. N. Hacker

H. T. Spark

CRTS-Corp.
Somewhere, UK.

ABSTRACT

This specification outlines the requirements and constraints of an MMCU for an entry in the Micromouse Competition. It is proposed that the target hardware for the MMCU will be either ASIC or CPLD based and NOT CPU based.

1. Problem Overview (Extracted from MicroMouse Competition Rules)

- a) The maze shall comprise 16×16 multiples of an $18\text{cm} \times 18\text{cm}$ unit square. The walls constituting the maze shall be 5cm high and 1.2cm thick. Passageways between the walls shall be 16.8cm wide. The outside wall shall enclose the entire maze.
- b) The side of the maze walls shall be white, and the top of the walls shall be red. The floor of the maze shall be made of wood and finished with a non-gloss black paint. The coating of the top and side of the wall shall be selected to reflect infra-red light and the coating on the floor shall absorb it.
- c) The start of the maze shall be located at one of the four corners. The starting square shall have walls on three sides. The starting square orientation shall be such that when the open wall is to the 'north', outside maze walls are on the 'west', and 'south'. At the center of the maze shall be a large opening composed of four (4) unit squares. This central square shall be the destination.
- d) Multiple paths to the destination square are allowed and are to be expected.
- e) Although the superstructure of the mice may 'bulge' above the top of the walls, mice must be subject to the following size constraints - width 25cm , length 25cm . Mice must be completely self-contained and receive no outside assistance.
- f) The method of wall sensing is at the discretion of the builder; however, the mouse must not exert a force on any wall likely to cause damage.
- g) The goal is to achieve the fastest time to the center of the maze. This is derived from the 'search', or 'maze', time and the 'run' time. A maximum time of ten minutes is permitted.

2. Specifications and Limitations

It has been decided to separate the functions of maze searching/mapping and motor control. You are required to develop the Micromouse Motor Control Unit (MMCU), leaving the mapping problem to another team.

After investigation it has been decided that the MMCU will utilise the wall sensing technique developed by the Department of Electrical & Electronic Engineering, Loughborough University (Fig. 1). These sensors will be combined with a forward pointing single sensor to provide early detection of a wall in front. The control system will therefore contain the following

- Left wall sensors
- Right wall sensors
- Forward sensor
- Left Motor control (Forward/Reverse/Stop)
- Right Motor control (Forward/Reverse/Stop)

The MMCU will shutdown on receipt of a 'time-up' signal. This will be generated by an external timer ten minutes after the start signal is received.

Note that the Loughborough design includes a visible light LED for monitoring the signal output from the sensor unit.

3. Design Requirements :

Your design will utilize the two-level digital TTL signals from the sensors to control the movement of the mouse. The mouse should stay centered within the corridor and make left and right turns as appropriate. The front sensor may be utilized, where possible, to avoid 'stop-reverse-turn' sequences as these will waste time. You may assume, initially that the floor is non-slip. and that 'on-the-spot' turns are possible.

The wheels are driven by DC motors and are independently controlled using a standard 'H bridge configuration' for forward and reverse (Fig. 3.i). The drive for the motors can be treated as on-off, i.e. no consideration need be given for varying the speed of the motors at this stage. The motors require two control signals each as shown in Figure 3.ii. These control signals are also two-level digital TTL signals.

The micromouse should halt when the allowed time is up or when the center of the maze has been reached. Consideration should be given to :-

- Whether the center of the maze can be identified by means of the input from the wall sensors?
- Whether the MMCU should track the position in the maze and whether this is appropriate given the specification.

The MMCU should respond appropriately to all the possible wall layouts permitted within the Competition Rules and as specified within this document.

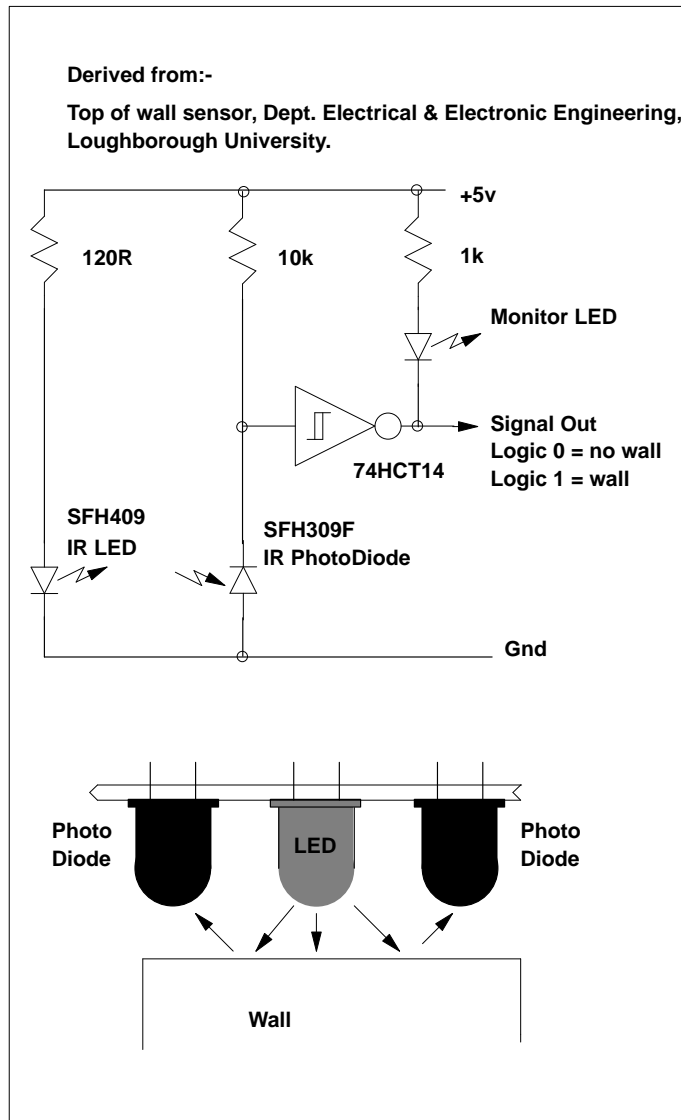

figure (1) Wall sensing

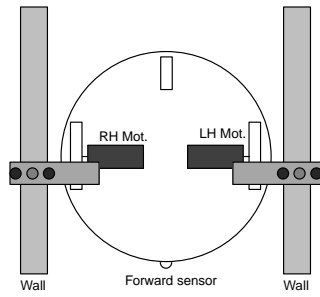

figure (2) Typical motor and sensor layout

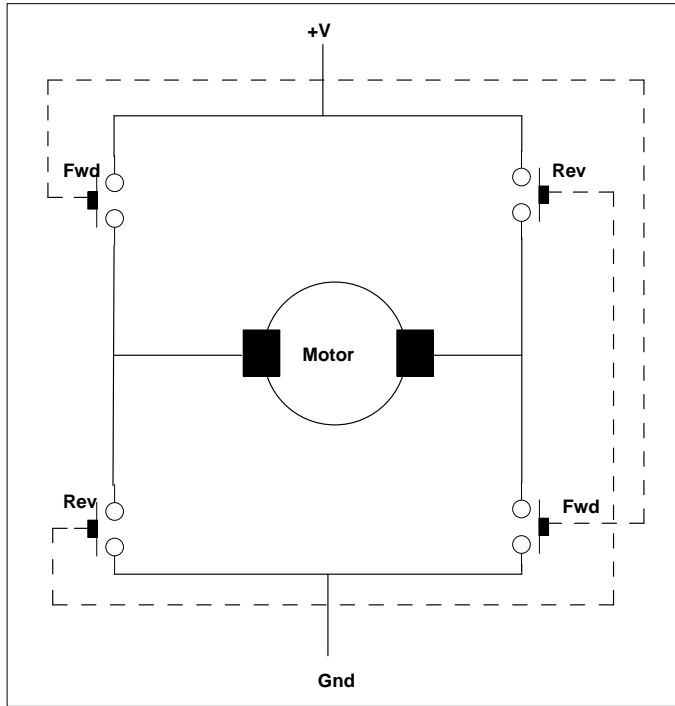

figure (3.i) Idealized model of H-bridge motor control

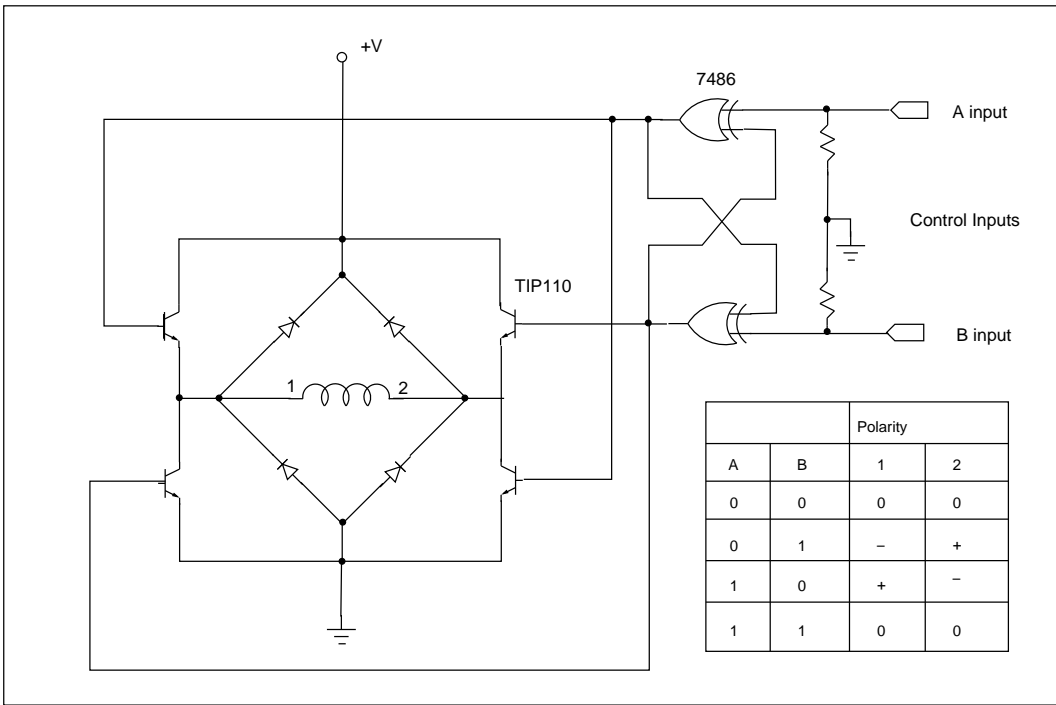

figure (3.ii) Possible implementation of forward/reverse control